

GET STARTED

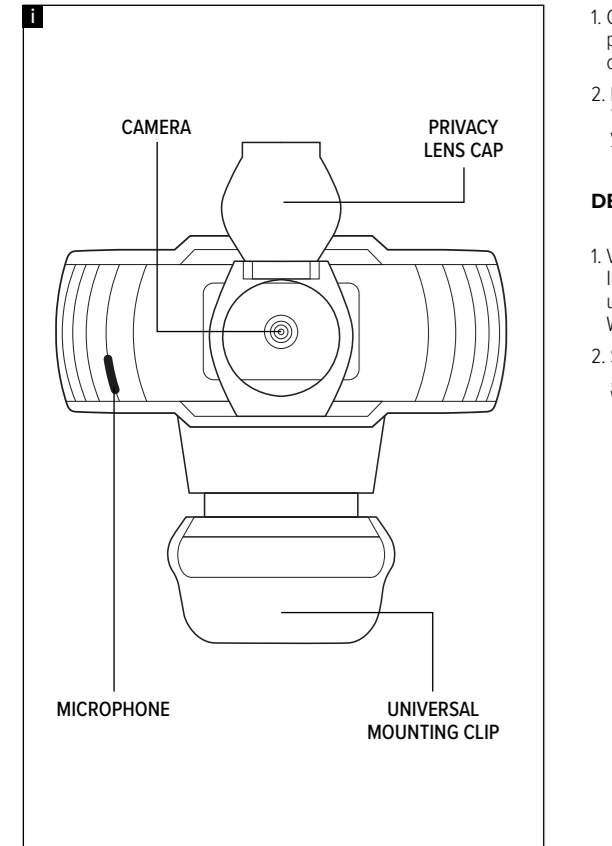

EN

1. Connect the webcam to a free USB port on your computer and place the camera on your monitor using the universal mounting clip. The webcam's vertical angle can be adjusted as desired.
2. Make sure to choose the video and audio settings "USB Camera" and "USB Audio" when using the webcam with your communication apps.

DE

1. Verbinden Sie die Webcam mit einem freien USB-Anschluss Ihres Computers und platzieren Sie die Kamera mit Hilfe des universellen Befestigungsclips auf Ihrem Monitor. Der vertikale Winkel der Webcam kann nach Belieben angepasst werden.
2. Stellen Sie sicher, dass die Video- und Audioeinstellungen „USB Camera“ und „USB Audio“ ausgewählt sind, wenn Sie die Webcam mit Ihren Kommunikations-Apps verwenden.

EN

Technical support: www.speedlink.com
Safety instructions: www.speedlink.com

- WEEE: Dispose the product at a recycling point. Do not dispose together with household waste. Incorrect storage/disposal can harm the environment and/or cause injury.

Speedlink declares that this product complies with the directives listed in the section "Conformity notice".

INTENDED USE

This product is intended to be used as an USB webcam for connecting to a computer and is for indoor home/office use only. It contains no user-serviceable parts. Do not disassemble it and stop using it immediately if damaged. Speedlink GmbH accepts no liability whatsoever for any damage to this product or injuries caused due to careless or improper use or for purposes for which it is not intended.

Please keep this information for later reference.

DE

Technischer Support: www.speedlink.com
Sicherheitshinweise: www.speedlink.com

- WEEE: Produkt bei einer Recyclingstelle abgeben. Nicht im Hausmüll entsorgen. Unsachgemäße Lagerung/Entsorgung kann der Umwelt und/oder Gesundheit schaden.

Speedlink erklärt, dass das Produkt den unter „Conformity notice“ aufgeführten Anforderungen entspricht.

BESTIMMUNGSGEMÄSSER GEBRAUCH

Dieses Produkt dient als USB-Webcam für den Heim- oder Bürogebrauch in trockenen, geschlossenen Räumen. Es ist wartungsfrei. Nicht öffnen oder bei Beschädigung nutzen. Die Speedlink GmbH übernimmt keine Haftung für Produktschäden oder Verletzungen von Personen durch unachtsame, unsachgemäße oder nicht dem angegebenen Zweck entsprechende Verwendung.

Bitte bewahren Sie diese Informationen zur künftigen Verwendung auf.

FR

Assistance technique: www.speedlink.com
Consignes de sécurité: www.speedlink.com

- WEEE: Déposer l'appareil dans une borne de recyclage. Ne pas le placer dans les ordures ménagères. Un stockage ou une élimination incorrects peuvent nuire à l'environnement et/ou à la santé.

Speedlink confirme que le produit est conforme aux exigences énoncées à la rubrique « Conformity notice ».

CADRE D'UTILISATION

Ce produit sert de webcam USB pour la connexion à un ordinateur à usage domestique ou professionnel dans des locaux fermés et secs. Il ne demande pas d'entretien. Ne pas l'ouvrir et ne pas l'utiliser s'il est abîmé. La société Speedlink GmbH décline toute responsabilité en cas de dégradations du produit ou de blessures dues à une utilisation inconsidérée, incorrecte ou contraire à la destination indiquée.

Veillez conserver ces informations afin de pouvoir vous y référer ultérieurement.

IT

Supporto tecnico: www.speedlink.com
Istruzioni di sicurezza: www.speedlink.com

- WEEE: Consegnare l'apparecchio a un impianto di recupero rifiuti. Non smaltire insieme ai rifiuti domestici. Un deposito/smaltimento improprio può danneggiare l'ambiente e/o la salute.

Speedlink dichiara che il prodotto è conforme ai requisiti indicati nella sezione „Conformity notice“.

Conservare esta información para consultarla en el futuro.

Техническая поддержка: www.speedlink.com
Указания по безопасности: www.speedlink.com

USO CONFORME ALLA DESTINAZIONE
Questo prodotto è destinato ad essere utilizzato come una webcam USB per il collegamento a un computer per uso domestico o in ufficio, in spazi asciutti e chiusi. Il prodotto non richiede manutenzione. Non aprire o usare in caso di danneggiamenti. La Speedlink GmbH non risponde di danni al prodotto o lesioni personali a seguito di un uso negligente, improprio o non conforme all'uso indicato.

Speedlink заявляет, что изделие отвечает требованиям, содержащимся в разделе «Conformity notice».

ИСПОЛЬЗОВАНИЕ ПО НАЗНАЧЕНИЮ

Данное изделие используется в качестве веб-камеры для подключения по USB к домашнему или офисному компьютеру в сухих закрытых помещениях. Оно не нуждается в техническом обслуживании. Не открывать и не использовать, если оно повреждено. Speedlink GmbH не несет ответственности за ущерб изделию или травмы лиц вследствие неосторожного, ненадлежащего, или не соответствующего указанной цели использования.

Speedlink declara que el producto cumple con los requisitos enumerados en „Conformity Notice“.

- WEEE: Entregar el dispositivo en el punto limpio. No depositar en contenedores de basura doméstica. El almacenamiento/eliminación inadecuada puede causar daños al medio ambiente y/o a la salud humana.

Speedlink declara que el producto cumple con los requisitos enumerados en „Conformity Notice“.

Este producto es una webcam que se conecta al ordenador a través de una conexión USB. Destinada a su uso en casa o en la oficina, siempre en espacios secos y cerrados. No necesita mantenimiento. No abrir ni utilizar si presenta daños o defectos. Speedlink GmbH no asume la responsabilidad por daños en el producto o lesiones corporales ocasionadas por una utilización inadecuada o impropia, diferente de la recomendada.

Este producto es una webcam que se conecta al ordenador a través de una conexión USB. Destinada a su uso en casa o en la oficina, siempre en espacios secos y cerrados. No necesita mantenimiento. No abrir ni utilizar si presenta daños o defectos. Speedlink GmbH no asume la responsabilidad por daños en el producto o lesiones corporales ocasionadas por una utilización inadecuada o impropia, diferente de la recomendada.

Speedlink erklärt, dass das Produkt den unter „Conformity notice“ aufgeführten Anforderungen entspricht.

Speedlink erklärt, dass das Produkt den unter „Conformity notice“ aufgeführten Anforderungen entspricht.

Speedlink erklärt, dass das Produkt den unter „Conformity notice“ aufgeführten Anforderungen entspricht.

Speedlink erklärt, dass das Produkt den unter „Conformity notice“ aufgeführten Anforderungen entspricht.

Speedlink erklärt, dass das Produkt den unter „Conformity notice“ aufgeführten Anforderungen entspricht.

WEEE: Sдать прибор в пункт приема и переработки отходов. Не выбрасывать в домашний мусор. Неправильное хранение/утилизация может нанести вред окружающей среде и/или здоровью.

Speedlink заявляет, что изделие отвечает требованиям, содержащимся в разделе «Conformity notice».

ИСПОЛЬЗОВАНИЕ ПО НАЗНАЧЕНИЮ

Данное изделие используется в качестве веб-камеры для подключения по USB к домашнему или офисному компьютеру в сухих закрытых помещениях. Оно не нуждается в техническом обслуживании. Не открывать и не использовать, если оно повреждено. Speedlink GmbH не несет ответственности за ущерб изделию или травмы лиц вследствие неосторожного, ненадлежащего, или не соответствующего указанной цели использования.

Speedlink declara que el producto cumple con los requisitos enumerados en „Conformity Notice“.

- WEEE: Entregar el dispositivo en el punto limpio. No depositar en contenedores de basura doméstica. El almacenamiento/eliminación inadecuada puede causar daños al medio ambiente y/o a la salud humana.

Speedlink declara que el producto cumple con los requisitos enumerados en „Conformity Notice“.

Este producto es una webcam que se conecta al ordenador a través de una conexión USB. Destinada a su uso en casa o en la oficina, siempre en espacios secos y cerrados. No necesita mantenimiento. No abrir ni utilizar si presenta daños o defectos. Speedlink GmbH no asume la responsabilidad por daños en el producto o lesiones corporales ocasionadas por una utilización inadecuada o impropia, diferente de la recomendada.

Este producto es una webcam que se conecta al ordenador a través de una conexión USB. Destinada a su uso en casa o en la oficina, siempre en espacios secos y cerrados. No necesita mantenimiento. No abrir ni utilizar si presenta daños o defectos. Speedlink GmbH no asume la responsabilidad por daños en el producto o lesiones corporales ocasionadas por una utilización inadecuada o impropia, diferente de la recomendada.

Speedlink erklärt, dass das Produkt den unter „Conformity notice“ aufgeführten Anforderungen entspricht.

Speedlink erklärt, dass das Produkt den unter „Conformity notice“ aufgeführten Anforderungen entspricht.

Speedlink erklärt, dass das Produkt den unter „Conformity notice“ aufgeführten Anforderungen entspricht.

Speedlink erklärt, dass das Produkt den unter „Conformity notice“ aufgeführten Anforderungen entspricht.

Speedlink erklärt, dass das Produkt den unter „Conformity notice“ aufgeführten Anforderungen entspricht.

PL
Pomoc techniczna: www.speedlink.com
Wskazówki bezpieczeństwa: www.speedlink.com

- WEEE: Oddać urządzenie do punktu utylizacji. Nie wyrzucać wraz z odpadami domowymi. Niewłaściwe przechowywanie/ utylizacja może szkodzić środowisku i/lub zdrowiu.

Speedlink oświadcza, że produkt spełnia wymagania wymienione w informacji o zgodności „Conformity notice“.

UŻYTKOWANIE ZGODNE Z PRZEZNACZENIEM

Niniejszy produkt stanowi kamerę internetową podłączaną do komputera do użytku w domu lub w biurze w suchych, zamkniętych pomieszczeniach. Nie wymaga on konserwacji. Nie otwierać ani nie korzystać z niego w celu uszkodzenia. Speedlink GmbH nie ponosi żadnej odpowiedzialności za uszkodzenia produktu lub obrażenia u ludzi spowodowane nieuważnym, nieodpowiednim lub niezgodnym z przeznaczeniem użytkowaniem produktu.

Speedlink declara que el producto cumple con los requisitos enumerados en „Conformity Notice“.

Speedlink declara que el producto cumple con los requisitos enumerados en „Conformity Notice“.

Speedlink declara que el producto cumple con los requisitos enumerados en „Conformity Notice“.

Speedlink declara que el producto cumple con los requisitos enumerados en „Conformity Notice“.

Speedlink declara que el producto cumple con los requisitos enumerados en „Conformity Notice“.

Speedlink declara que el producto cumple con los requisitos enumerados en „Conformity Notice“.

Speedlink declara que el producto cumple con los requisitos enumerados en „Conformity Notice“.

Speedlink declara que el producto cumple con los requisitos enumerados en „Conformity Notice“.

Speedlink declara que el producto cumple con los requisitos enumerados en „Conformity Notice“.

ha gondatlan, szakszerűtlen vagy nem a célnak megfelelő használatból ered.

Kérem, ezt az információt tartsa meg referenciaként.

GR

Τεχνική υποστήριξη: www.speedlink.com
Υποδείξεις ασφαλείας: www.speedlink.com

- WEEE: Παραδώστε τη συσκευή σε ένα κέντρο ανακύκλωσης. Μην το απορρίπτετε στα οικιακά απορρίμματα. Ακατάλληλη απόρριψη/διάθεση μπορεί να προκαλέσει ζημιά στο περιβάλλον ή/και στην υγεία.

Η Speedlink δηλώνει ότι το προϊόν πληροί τις αναφερόμενες απαιτήσεις στη «Conformity notice».

Η Speedlink δηλώνει ότι το προϊόν πληροί τις αναφερόμενες απαιτήσεις στη «Conformity notice».

Η Speedlink δηλώνει ότι το προϊόν πληροί τις αναφερόμενες απαιτήσεις στη «Conformity notice».

Η Speedlink δηλώνει ότι το προϊόν πληροί τις αναφερόμενες απαιτήσεις στη «Conformity notice».

Η Speedlink δηλώνει ότι το προϊόν πληροί τις αναφερόμενες απαιτήσεις στη «Conformity notice».

Η Speedlink δηλώνει ότι το προϊόν πληροί τις αναφερόμενες απαιτήσεις στη «Conformity notice».

Η Speedlink δηλώνει ότι το προϊόν πληροί τις αναφερόμενες απαιτήσεις στη «Conformity notice».

Η Speedlink δηλώνει ότι το προϊόν πληροί τις αναφερόμενες απαιτήσεις στη «Conformity notice».

Η Speedlink δηλώνει ότι το προϊόν πληροί τις αναφερόμενες απαιτήσεις στη «Conformity notice».

Η Speedlink δηλώνει ότι το προϊόν πληροί τις αναφερόμενες απαιτήσεις στη «Conformity notice».

Η Speedlink δηλώνει ότι το προϊόν πληροί τις αναφερόμενες απαιτήσεις στη «Conformity notice».

opbevaring/bortskaffelse kan være skadeligt for miljøet og/eller helbredet.

Speedlink forklarer, at produktet svarer til de krav som er beskrevet i „Conformity notice“.

KORREKT ANVENDELSE

Dette produkt fungerer som et USB-webkamera som kan sluttes til en computer og bruges både derhjemme, på kontoret eller i ethvert tort, lukket rum. Det er vedligeholdelsesfrit. Må ikke åbnes eller bruges, hvis det er beskadiget. Speedlink GmbH giver ikke garanti for skader på produktet eller personskader, som er forårsaget af uagtsom, uhensigtsmæssig eller forkert anvendelse eller anvendelse, som ikke er i overensstemmelse med det angivne formål.

PT

Suporte técnico: www.speedlink.com
Avisos de segurança: www.speedlink.com

- WEEE: Entregar o aparelho num ponto de reciclagem. Não eliminar no lixo doméstico. O armazenamento/eliminação incorreta pode prejudicar o meio ambiente e/ou a saúde.

Speedlink declara, que o produto corresponde aos requisitos mencionados na «Conformity notice».

Speedlink declara, que o produto corresponde aos requisitos mencionados na «Conformity notice».

Speedlink declara, que o produto corresponde aos requisitos mencionados na «Conformity notice».

Speedlink declara, que o produto corresponde aos requisitos mencionados na «Conformity notice».

Speedlink declara, que o produto corresponde aos requisitos mencionados na «Conformity notice».

Speedlink declara, que o produto corresponde aos requisitos mencionados na «Conformity notice».

Speedlink declara, que o produto corresponde aos requisitos mencionados na «Conformity notice».

Speedlink declara, que o produto corresponde aos requisitos mencionados na «Conformity notice».

opbevaring/bortskaffelse kan være skadeligt for miljøet og/eller helbredet.

Speedlink forklarer, at produktet svarer til de krav som er beskrevet i „Conformity notice“.

KORREKT ANVENDELSE

Dette produkt fungerer som et USB-webkamera som kan sluttes til en computer og bruges både derhjemme, på kontoret eller i ethvert tort, lukket rum. Det er vedligeholdelsesfrit. Må ikke åbnes eller bruges, hvis det er beskadiget. Speedlink GmbH giver ikke garanti for skader på produktet eller personskader, som er forårsaget af uagtsom, uhensigtsmæssig eller forkert anvendelse eller anvendelse, som ikke er i overensstemmelse med det angivne formål.

PT

Suporte técnico: www.speedlink.com
Avisos de segurança: www.speedlink.com

- WEEE: Entregar o aparelho num ponto de reciclagem. Não eliminar no lixo doméstico. O armazenamento/eliminação incorreta pode prejudicar o meio ambiente e/ou a saúde.

Speedlink declara, que o produto corresponde aos requisitos mencionados na «Conformity notice».

Speedlink declara, que o produto corresponde aos requisitos mencionados na «Conformity notice».

Speedlink declara, que o produto corresponde aos requisitos mencionados na «Conformity notice».

Speedlink declara, que o produto corresponde aos requisitos mencionados na «Conformity notice».

Speedlink declara, que o produto corresponde aos requisitos mencionados na «Conformity notice».

Speedlink declara, que o produto corresponde aos requisitos mencionados na «Conformity notice».

Speedlink declara, que o produto corresponde aos requisitos mencionados na «Conformity notice».

Speedlink declara, que o produto corresponde aos requisitos mencionados na «Conformity notice».

opbevaring/bortskaffelse kan være skadeligt for miljøet og/eller helbredet.

Speedlink forklarer, at produktet svarer til de krav som er beskrevet i „Conformity notice“.

KORREKT ANVENDELSE

Dette produkt fungerer som et USB-webkamera som kan sluttes til en computer og bruges både derhjemme, på kontoret eller i ethvert tort, lukket rum. Det er vedligeholdelsesfrit. Må ikke åbnes eller bruges, hvis det er beskadiget. Speedlink GmbH giver ikke garanti for skader på produktet eller personskader, som er forårsaget af uagtsom, uhensigtsmæssig eller forkert anvendelse eller anvendelse, som ikke er i overensstemmelse med det angivne formål.

PT

Suporte técnico: www.speedlink.com
Avisos de segurança: www.speedlink.com

- WEEE: Entregar o aparelho num ponto de reciclagem. Não eliminar no lixo doméstico. O armazenamento/eliminação incorreta pode prejudicar o meio ambiente e/ou a saúde.

Speedlink declara, que o produto corresponde aos requisitos mencionados na «Conformity notice».

Speedlink declara, que o produto corresponde aos requisitos mencionados na «Conformity notice».

Speedlink declara, que o produto corresponde aos requisitos mencionados na «Conformity notice».

Speedlink declara, que o produto corresponde aos requisitos mencionados na «Conformity notice».

Speedlink declara, que o produto corresponde aos requisitos mencionados na «Conformity notice».

Speedlink declara, que o produto corresponde aos requisitos mencionados na «Conformity notice».

Speedlink declara, que o produto corresponde aos requisitos mencionados na «Conformity notice».

Speedlink declara, que o produto corresponde aos requisitos mencionados na «Conformity notice».



www.speedlink.com

SL-601801-BK

otvarajte i koristiti ako je oštećen. Tvrtka Speedlink GmbH ne preuzima nikakvu odgovornost za štete na proizvodu ili ozljede nastale nepažljivom i nenamjenskom uporabom, ili uporabom koja nije u skladu s navedenom svrhom proizvoda.

Molimo Vas sačuvajte ove informacije za buduću uporabu.

RS

Tehnička podrška: www.speedlink.com

Sigurnosne napomene: www.speedlink.com

 WEEE: Predajte uređaj kod centra za reciklažu. Ne odlažite u kućni otpad. Nepropisno skladištenje/odlaganje može da bude štetno za životnu sredinu i/ili zdravlje.

Speedlink izjavljuje da je proizvod u skladu sa zahtevima iz „Conformity notice“.

NAMENSKA UPOTREBA

Ovaj proizvod se koristi kao USB veb-kamera za povezivanje sa računarom i namenjen je za kućnu ili kancelarijsku upotrebu u svim i zatvorenim prostorima. Nije potrebno održavanje. Nemojte otvarati ili koristiti ako je oštećen. Preduzeće Speedlink GmbH ne preuzima odgovornost za štete na proizvodu ili povrede osoba usled nepažljive i nestručne primene ili usled korišćenja koje nije u skladu s navedenom svrhom.

Sačuvajte ove informacije za kasniju upotrebu.

SL

Tehnična podpora: www.speedlink.com

Varnostna navodila: www.speedlink.com

 WEEE: Napravo oddajte mestu za recikliranje odpadkov. Ne zavrzite med gospodinjske odpadke. Nepravilno skladiščenje/odlaganje med odpadke lahko škoduje okolju in/ali zdravju.

Speedlink izjavlja, da izdelek izpolnjuje zahteve, navedene v »Conformity notice«.

PREVIDIDENA UPORABA

Ta izdelek se uporablja kot spletna kamera USB za povezavo z računalnikom za domačo ali pisarniško uporabo v suhih, zaprtih prostorih. Izdelka ni treba vzdrževati. Izdelka ne odpirajte in ga ne uporabljajte poškodovanega. Družba Speedlink GmbH ne prevzema nikakršne odgovornosti za škodo na izdelku ali telesne poškodbe oseb na podlagi nepažljive, neustrezne uporabe izdelka ali njegove uporabe za namene, ki ne ustrezajo navedbam proizvajalca o ustrezni uporabi izdelka.

Prosimo vas, da te informacije shranite za prihodnjo rabo.

EE

Tehniline tugi: www.speedlink.com

Ohutusnõuded: www.speedlink.com

 WEEE: Andke seade taaskasutuse kogumispunkti. Mitte käidelda olmeprügis. Asjakohatu laagerdamine/käitlemine võib kahjustada keskkonda ja/või tervist.

Speedlink kinnitab, et toode vastab „Conformity notice“ all toodud tingimustele.

NÕUETEKOHANE KASUTAMINE

See toode on ette nähtud kasutamiseks arvutiga ühendatud USB-veebikaamerana kuivades, suletud ruumides kodus või kontoris. Seade on hooldevaba. Seadet ei tohi avada ega selle kahjustuste korral kasutada. Speedlink GmbH ei võta vastutust hooletust, asjatundmatust või mitteotstarbekohasest kasutamisest tingitud inimvigastuste või varakahjude eest.

Säilitage see infoleht tulevaseks kasutamiseks.

EG

قسم الدعم الفني: www.speedlink.com

إرشادات السلامة: www.speedlink.com

 WEEE: سلم الجهاز إلى شركة تدوير النفايات. لا تتخلص منه عبر المهملات المنزلية. التخزين أو التخلص من الجهاز بطريقة غير سليمة قد يسببان أضرارًا بالبيئة أو الصحة أو كليهما.

تُعلن شركة Speedlink أن المنتج مطابق للمتطلبات المنصوص عليها تحت بند „Conformity notice“.

الاستخدام المطابق للتعليمات هذا المنتج عبارة عن كاميرا ويب USB مخصصة للاتصال بجهاز كمبيوتر في بيئة منزلية أو مكتبية جافة. وهو لا يحتاج للصيانة. لا تفتحه ولا تستخدمه حال تعرضه للضرر. لا تتحمل شركة Speedlink GmbH أية مسؤولية عن أضرار المنتجات أو تعرض الأفراد للإصابة بسبب الاستخدام غير الواعي أو غير المطابق للتعليمات أو غير المطابق لغرض الاستخدام المقرر.

برجاء الاحتفاظ بهذه المعلومات من أجل استخدامها في وقت لاحق.

IL

תמיכה טכנית: www.speedlink.com

הוראות בטיחות: www.speedlink.com

 WEEE: העבר את המכשיר לנקודת מיחזור. אין להשליך לפסולת ביתית. אחסון / סילוק לא תקין עלול להזיק לסביבה ו / או לבריאות.

Speedlink מצהיר, כי המוצר עומד בדרישות המפורטות של ה- „Conformity notice“.

שימוש על פי היעוד

מוצר זה הוא מצלמת רשת בחיבור USB המיועדת להתחבר למחשב בסביבת פנים ביתית ויבשה, או בסביבה משרדית. אין צורך בתחזוקה של המכשיר. אין לפתוח את המכשיר, ואין להשתמש במכשיר פגום. חברת Speedlink GmbH אינה אחראית לנזקים במוצר, או לפגיעות גוף, הנגרמים על ידי שימוש לא זהיר, לא מתאים, או למטרות שונות מהמטרה המיועדת.

אנא שמור מידע זה לשימוש עתידי.

BG

Техническа поддръжка: www.speedlink.com

Указания за безопасност: www.speedlink.com

 WEEE: Предайте уреда в пункт за рециклиране. Не изхвърляйте в домакинската смет. Неpravилно съхранение/изхвърляне може да навреди на околната среда и/или здравето.

Speedlink декларира, че продуктът отговаря на посочените в точка „Conformity notice“ изисквания.

УПОТРЕБА ПО ПРЕДНАЗНАЧЕНИЕ

Този продукт служи като USB Webcam за свързване към компютър за употреба в къщи или в офис в сухи, затворени помещения. Той не се нуждае от поддръжка. Не отваряйте и не използвайте при повреда. Фирма Speedlink GmbH не поема отговорност за повреди на продукта или наранявания на лица в резултат на невнимателна, неправилна или несъответстваща на посоченото предназначение употреба.

Моля, запазете тази информация за бъдеща употреба.

SK

Technická podpora: www.speedlink.com

Bezpečnostné pokyny: www.speedlink.com

 WEEE: Prístroj odovzdajte na recyklačné miesto. Nelikvidujte v domovom odpade. Neodborné skladovanie/likvidácia môže škodiť životnému prostrediu a/alebo zdraviu.

Spoločnosť Speedlink vyhlasuje, že produkt zodpovedá požiadavkám uvedeným pod „Conformity notice“.

POUŽÍVANIE NA URČENÝ ÚČEL

Tento výrobok slúži ako webkamera na pripojenie k počítaču, a na domáce alebo kancelárske použitie v suchých, uzatvorených priestoroch. Nevyžaduje údržbu. Neotvárajte ani pro poškodení nepoužívajte. Spoločnosť Speedlink GmbH nepreberá žiadne

ručenie za škody na produktoch alebo poranenia osôb v dôsledku neopatrného, neodborného používania alebo používania nezodpovedajúceho uvedenému účelu.

Túto informáciu uchovajte, prosím, pre budúce použitie.

SAFETY INSTRUCTIONS

IMPORTANT SAFETY INSTRUCTIONS

 Please note that the failure to observe these instructions can cause product damage, explosion, fire and/or electric shocks!

• Only use the devices as indicated in the user guide. Do not open or repair them.

• Do not expose the devices to liquids, heat or cold.

• Do not use the devices in a damp environment. Clean the device with a dry cloth.

• Keep the devices and all loose parts away from children, pets and unauthorized persons.

• Only use the devices with the appropriate provided accessories/cables.

• Disconnect cables from the devices if they will not be used for a long time. When disconnecting the cables, don't pull on the cord but on the plug.

• Don't use the cables in any way other than mentioned in the user guide; don't bend, cut, extend, knot or step on them.

• Do not insert any foreign objects into the openings of the device.

• If the devices are damaged in any way or get too hot, stop using them immediately.

• Take caution when using devices that emit radio signals if you have a pacemaker or are dependent on other sensitive electronic life aids.

Safety instructions in further languages: www.speedlink.com.

WICHTIGE SICHERHEITSHINWEISE

 Die Nichtbeachtung dieser Hinweise kann zu Schäden am Produkt, Explosionen, Feuer oder elektrischen Schocks führen!

• Produkte nur entsprechend der Gebrauchsanleitung verwenden. Nicht öffnen oder reparieren.

• Produkte keinen Flüssigkeiten, Hitze oder Kälte aussetzen.

• Produkte nicht in einer feuchten Umgebung nutzen. Mit einem trockenen Tuch reinigen.

• Produkte und alle losen Teile von Kindern, Haustieren und unbefugten Personen fernhalten.

• Produkte nur mit dem mitgelieferten Zubehör nutzen/aufladen.

• Kabel von Produkten abziehen, wenn sie längere Zeit nicht verwendet werden. Beim Abziehen nicht am Kabel, sondern am Stecker ziehen.

• Kabel nur gemäß Gebrauchsanleitung verwenden; nicht knicken, verlängern oder verknoten; nicht einschneiden oder darauf treten.

• Keine fremden Objekte in die Öffnungen von Produkten einführen.

• Bei Beschädigung oder Überhitzung der Produkte sofort die Benutzung abbrechen.

• Vorsicht bei Abhängigkeit von Herzschrittmachern oder anderen empfindlichen elektronischen Lebenshilfen, wenn Produkte Funksignale aussenden.

Sicherheitshinweise in weiteren Sprachen: www.speedlink.com.

WARNING SYMBOLS AND MARKINGS

Extended use of input devices may cause health problems such as discomfort or pain; as such, take regular breaks and consult a doctor if problems persist.

 Bei extrem langer Benutzung von Eingabegeräten kann es zu gesundheitlichen Beschwerden wie Unbehagen oder Schmerzen kommen. Legen Sie regelmäßig Pausen ein und holen Sie bei wiederkehrenden Problemen ärztlichen Rat ein.

Conformity notice in further languages: www.speedlink.com

KONFORMITÄTSHINWEIS Unter Einwirkung von starken statischen, elektrischen oder hochfrequenten Feldern (Funkanlagen, Mobiltelefone, Mikrowellen, elektrostatische Entladungen) kann es zu Funktionsbeeinträchtigungen des Gerätes (der Geräte) kommen. Versuchen Sie in diesem Fall, die Distanz zu den störenden Geräten zu vergrößern.

Konformitätshinweis in weiteren Sprachen: www.speedlink.com

CONFORMITY NOTICE

Operation of the device (the devices) may be affected by strong static, electrical or high-frequency fields (radio installations, mobile telephones, microwaves, electrostatic discharges). If this occurs, try increasing the distance from the devices causing the interference.

Conformity notice in further languages: www.speedlink.com

CONFORMITY NOTICE

Operation of the device (the devices) may be affected by strong static, electrical or high-frequency fields (radio installations, mobile telephones, microwaves, electrostatic discharges). If this occurs, try increasing the distance from the devices causing the interference.

CONFORMITY NOTICE

Operation of the device (the devices) may be affected by strong static, electrical or high-frequency fields (radio installations, mobile telephones, microwaves, electrostatic discharges). If this occurs, try increasing the distance from the devices causing the interference.

CONFORMITY NOTICE

Operation of the device (the devices) may be affected by strong static, electrical or high-frequency fields (radio installations, mobile telephones, microwaves, electrostatic discharges). If this occurs, try increasing the distance from the devices causing the interference.

Operation of the device (the devices) may be affected by strong static, electrical or high-frequency fields (radio installations, mobile telephones, microwaves, electrostatic discharges). If this occurs, try increasing the distance from the devices causing the interference.

Operation of the device (the devices) may be affected by strong static, electrical or high-frequency fields (radio installations, mobile telephones, microwaves, electrostatic discharges). If this occurs, try increasing the distance from the devices causing the interference.

Operation of the device (the devices) may be affected by strong static, electrical or high-frequency fields (radio installations, mobile telephones, microwaves, electrostatic discharges). If this occurs, try increasing the distance from the devices causing the interference.

Operation of the device (the devices) may be affected by strong static, electrical or high-frequency fields (radio installations, mobile telephones, microwaves, electrostatic discharges). If this occurs, try increasing the distance from the devices causing the interference.

Operation of the device (the devices) may be affected by strong static, electrical or high-frequency fields (radio installations, mobile telephones, microwaves, electrostatic discharges). If this occurs, try increasing the distance from the devices causing the interference.

Operation of the device (the devices) may be affected by strong static, electrical or high-frequency fields (radio installations, mobile telephones, microwaves, electrostatic discharges). If this occurs, try increasing the distance from the devices causing the interference.

Operation of the device (the devices) may be affected by strong static, electrical or high-frequency fields (radio installations, mobile telephones, microwaves, electrostatic discharges). If this occurs, try increasing the distance from the devices causing the interference.

Operation of the device (the devices) may be affected by strong static, electrical or high-frequency fields (radio installations, mobile telephones, microwaves, electrostatic discharges). If this occurs, try increasing the distance from the devices causing the interference.

Operation of the device (the devices) may be affected by strong static, electrical or high-frequency fields (radio installations, mobile telephones, microwaves, electrostatic discharges). If this occurs, try increasing the distance from the devices causing the interference.

Operation of the device (the devices) may be affected by strong static, electrical or high-frequency fields (radio installations, mobile telephones, microwaves, electrostatic discharges). If this occurs, try increasing the distance from the devices causing the interference.

Operation of the device (the devices) may be affected by strong static, electrical or high-frequency fields (radio installations, mobile telephones, microwaves, electrostatic discharges). If this occurs, try increasing the distance from the devices causing the interference.

Operation of the device (the devices) may be affected by strong static, electrical or high-frequency fields (radio installations, mobile telephones, microwaves, electrostatic discharges). If this occurs, try increasing the distance from the devices causing the interference.

Operation of the device (the devices) may be affected by strong static, electrical or high-frequency fields (radio installations, mobile telephones, microwaves, electrostatic discharges). If this occurs, try increasing the distance from the devices causing the interference.

Operation of the device (the devices) may be affected by strong static, electrical or high-frequency fields (radio installations, mobile telephones, microwaves, electrostatic discharges). If this occurs, try increasing the distance from the devices causing the interference.

Operation of the device (the devices) may be affected by strong static, electrical or high-frequency fields (radio installations, mobile telephones, microwaves, electrostatic discharges). If this occurs, try increasing the distance from the devices causing the interference.

Operation of the device (the devices) may be affected by strong static, electrical or high-frequency fields (radio installations, mobile telephones, microwaves, electrostatic discharges). If this occurs, try increasing the distance from the devices causing the interference.

Operation of the device (the devices) may be affected by strong static, electrical or high-frequency fields (radio installations, mobile telephones, microwaves, electrostatic discharges). If this occurs, try increasing the distance from the devices causing the interference.

Operation of the device (the devices) may be affected by strong static, electrical or high-frequency fields (radio installations, mobile telephones, microwaves, electrostatic discharges). If this occurs, try increasing the distance from the devices causing the interference.

Operation of the device (the devices) may be affected by strong static, electrical or high-frequency fields (radio installations, mobile telephones, microwaves, electrostatic discharges). If this occurs, try increasing the distance from the devices causing the interference.

Operation of the device (the devices) may be affected by strong static, electrical or high-frequency fields (radio installations, mobile telephones, microwaves, electrostatic discharges). If this occurs, try increasing the distance from the devices causing the interference.

Operation of the device (the devices) may be affected by strong static, electrical or high-frequency fields (radio installations, mobile telephones, microwaves, electrostatic discharges). If this occurs, try increasing the distance from the devices causing the interference.

Operation of the device (the devices) may be affected by strong static, electrical or high-frequency fields (radio installations, mobile telephones, microwaves, electrostatic discharges). If this occurs, try increasing the distance from the devices causing the interference.

Operation of the device (the devices) may be affected by strong static, electrical or high-frequency fields (radio installations, mobile telephones, microwaves, electrostatic discharges). If this occurs, try increasing the distance from the devices causing the interference.

Operation of the device (the devices) may be affected by strong static, electrical or high-frequency fields (radio installations, mobile telephones, microwaves, electrostatic discharges). If this occurs, try increasing the distance from the devices causing the interference.

Operation of the device (the devices) may be affected by strong static, electrical or high-frequency fields (radio installations, mobile telephones, microwaves, electrostatic discharges). If this occurs, try increasing the distance from the devices causing the interference.

Operation of the device (the devices) may be affected by strong static, electrical or high-frequency fields (radio installations, mobile telephones, microwaves, electrostatic discharges). If this occurs, try increasing the distance from the devices causing the interference.

Operation of the device (the devices) may be affected by strong static, electrical or high-frequency fields (radio installations, mobile telephones, microwaves, electrostatic discharges). If this occurs, try increasing the distance from the devices causing the interference.

Operation of the device (the devices) may be affected by strong static, electrical or high-frequency fields (radio installations, mobile telephones, microwaves, electrostatic discharges). If this occurs, try increasing the distance from the devices causing the interference.

Operation of the device (the devices) may be affected by strong static, electrical or high-frequency fields (radio installations, mobile telephones, microwaves, electrostatic discharges). If this occurs, try increasing the distance from the devices causing the interference.

Operation of the device (the devices) may be affected by strong static, electrical or high-frequency fields (radio installations, mobile telephones, microwaves, electrostatic discharges). If this occurs, try increasing the distance from the devices causing the interference.

Operation of the device (the devices) may be affected by strong static, electrical or high-frequency fields (radio installations, mobile telephones, microwaves, electrostatic discharges). If this occurs, try increasing the distance from the devices causing the interference.

Operation of the device (the devices) may be affected by strong static, electrical or high-frequency fields (radio installations, mobile telephones, microwaves, electrostatic discharges). If this occurs, try increasing the distance from the devices causing the interference.

Operation of the device (the devices) may be affected by strong static, electrical or high-frequency fields (radio installations, mobile telephones, microwaves, electrostatic discharges). If this occurs, try increasing the distance from the devices causing the interference.

Operation of the device (the devices) may be affected by strong static, electrical or high-frequency fields (radio installations, mobile telephones, microwaves, electrostatic discharges). If this occurs, try increasing the distance from the devices causing the interference.

Operation of the device (the devices) may be affected by strong static, electrical or high-frequency fields (radio installations, mobile telephones, microwaves, electrostatic discharges). If this occurs, try increasing the distance from the devices causing the interference.

Operation of the device (the devices) may be affected by strong static, electrical or high-frequency fields (radio installations, mobile telephones, microwaves, electrostatic discharges). If this occurs, try increasing the distance from the devices causing the interference.

Operation of the device (the devices) may be affected by strong static, electrical or high-frequency fields (radio installations, mobile telephones, microwaves, electrostatic discharges). If this occurs, try increasing the distance from the devices causing the interference.

Operation of the device (the devices) may be affected by strong static, electrical or high-frequency fields (radio installations, mobile telephones, microwaves, electrostatic discharges). If this occurs, try increasing the distance from the devices causing the interference.

Operation of the device (the devices) may be affected by strong static, electrical or high-frequency fields (radio installations, mobile telephones, microwaves, electrostatic discharges). If this occurs, try increasing the distance from the devices causing the interference.

Operation of the device (the devices) may be affected by strong static, electrical or high-frequency fields (radio installations, mobile telephones, microwaves, electrostatic discharges). If this occurs, try increasing the distance from the devices causing the interference.

Operation of the device (the devices) may be affected by strong static, electrical or high-frequency fields (radio installations, mobile telephones, microwaves, electrostatic discharges). If this occurs, try increasing the distance from the devices causing the interference.

Operation of the device (the devices) may be affected by strong static, electrical or high-frequency fields (radio installations, mobile telephones, microwaves, electrostatic discharges). If this occurs, try increasing the distance from the devices causing the interference.

Operation of the device (the devices) may be affected by strong static, electrical or high-frequency fields (radio installations, mobile telephones, microwaves, electrostatic discharges). If this occurs, try increasing the distance from the devices causing the interference.

Operation of the device (the devices) may be affected by strong static, electrical or high-frequency fields (radio installations, mobile telephones, microwaves, electrostatic discharges). If this occurs, try increasing the distance from the devices causing the interference.

Operation of the device (the devices) may be affected by strong static, electrical or high-frequency fields (radio installations, mobile telephones, microwaves, electrostatic discharges). If this occurs, try increasing the distance from the devices causing the interference.

Operation of the device (the devices) may be affected by strong static, electrical or high-frequency fields (radio installations, mobile telephones, microwaves, electrostatic discharges). If this occurs, try increasing the distance from the devices causing the interference.

Operation of the device (the devices) may be affected by strong static, electrical or high-frequency fields (radio installations, mobile telephones, microwaves, electrostatic discharges). If this occurs, try increasing the distance from the devices causing the interference.

Operation of the device (the devices) may be affected by strong static, electrical or high-frequency fields (radio installations, mobile telephones, microwaves, electrostatic discharges). If this occurs, try increasing the distance from the devices causing the interference.

Operation of the device (the devices) may be affected by strong static, electrical or high-frequency fields (radio installations, mobile telephones, microwaves, electrostatic discharges). If this occurs, try increasing the distance from the devices causing the interference.

Operation of the device (the devices) may be affected by strong static, electrical or high-frequency fields (radio installations, mobile telephones, microwaves, electrostatic discharges). If this occurs, try increasing the distance from the devices causing the interference.

Operation of the device (the devices) may be affected by strong static, electrical or high-frequency fields (radio installations, mobile telephones, microwaves, electrostatic discharges). If this occurs, try increasing the distance from the devices causing the interference.

Operation of the device (the devices) may be affected by strong static, electrical or high-frequency fields (radio installations, mobile telephones, microwaves, electrostatic discharges). If this occurs, try increasing the distance from the devices causing the interference.

Operation of the device (the devices) may be affected by strong static, electrical or high-frequency fields (radio installations, mobile telephones, microwaves, electrostatic discharges). If this occurs, try increasing the distance from the devices causing the interference.

Operation of the device (the devices) may be affected by strong static, electrical or high-frequency fields (radio installations, mobile telephones, microwaves, electrostatic discharges). If this occurs, try increasing the distance from the devices causing the interference.

Operation of the device (the devices) may be affected by strong static, electrical or high-frequency fields (radio installations, mobile telephones, microwaves, electrostatic discharges). If this occurs, try increasing the distance from the devices causing the interference.

Operation of the device (the devices) may be affected by strong static, electrical or high-frequency fields (radio installations, mobile telephones, microwaves, electrostatic discharges). If this occurs, try increasing the distance from the devices causing the interference.

Operation of the device (the devices) may be affected by strong static, electrical or high-frequency fields (radio installations, mobile telephones, microwaves, electrostatic discharges). If this occurs, try increasing the distance from the devices causing the interference.

Operation of the device (the devices) may be affected by strong static, electrical or high-frequency fields (radio installations, mobile telephones, microwaves, electrostatic discharges). If this occurs, try increasing the distance from the devices causing the interference.

Operation of the device (the devices) may be affected by strong static, electrical or high-frequency fields (radio installations, mobile telephones, microwaves, electrostatic discharges). If this occurs, try increasing the distance from the devices causing the interference.

Operation of the device (the devices) may be affected by strong static, electrical or high-frequency fields (radio installations, mobile telephones, microwaves, electrostatic discharges). If this occurs, try increasing the distance from the devices causing the interference.

Operation of the device (the devices) may be affected by strong static, electrical or high-frequency fields (radio installations, mobile telephones, microwaves, electrostatic discharges). If this occurs, try increasing the distance from the devices causing the interference.

Operation of the device (the devices) may be affected by strong static, electrical or high-frequency fields (radio installations, mobile telephones, microwaves, electrostatic discharges). If this occurs, try increasing the distance from the devices causing the interference.

Operation of the device (the devices) may be affected by strong static, electrical or high-frequency fields (radio installations, mobile telephones, microwaves, electrostatic discharges). If this occurs, try increasing the distance from the devices causing the interference.

Operation of the device (the devices) may be affected by strong static, electrical or high-frequency fields (radio installations, mobile telephones, microwaves, electrostatic discharges). If this occurs, try increasing the distance from the devices causing the interference.

Operation of the device (the devices) may be affected by strong static, electrical or high-frequency fields (radio installations, mobile telephones, microwaves, electrostatic discharges). If this occurs, try increasing the distance from the devices causing the interference.

Operation of the device (the devices) may be affected by strong static, electrical or high-frequency fields (radio installations, mobile telephones, microwaves, electrostatic discharges). If this occurs, try increasing the distance from the devices causing the interference.

Operation of the device (the devices) may be affected by strong static, electrical or high-frequency fields (radio installations, mobile telephones, microwaves, electrostatic discharges). If this occurs, try increasing the distance from the devices causing the interference.

Operation of the device (the devices) may be affected by strong static, electrical or high-frequency fields (radio installations, mobile telephones, microwaves, electrostatic discharges). If this occurs